

Review of Asymmetric Selective Harmonic Current Mitigation-PWM in Active Power Filters

¹Atul Kumar, ²Prof. Santosh Kumar

¹Research Scholar, Dept of Electrical and Electronics Engineering, Millennium Institute of Technology and Science, India

²Assistant Professor, Dept of Electrical and Electronics Engineering, Millennium Institute of Technology and Science, India

Abstract— In the realm of power quality enhancement and harmonic mitigation, active power filters (APFs) play a pivotal role in maintaining a stable and efficient electrical network. This paper reviews the application of Asymmetric Selective Harmonic Current Mitigation Pulse Width Modulation (PWM) techniques in active power filters. Asymmetric Selective Harmonic Current Mitigation-PWM, an innovative approach in the field, offers targeted harmonic reduction and improved filtering capabilities. This review delves into the underlying principles of Asymmetric Selective Harmonic Current Mitigation-PWM, explores its advantages over conventional methods, and provides insights into its implementation in active power filters. The paper also discusses recent advancements, challenges, and potential future directions for further research in this dynamic area of power electronics.

Keywords— Asymmetric, Harmonic, PWM, Active, Power Filters.

I. INTRODUCTION

The increasing integration of nonlinear loads and power electronics in modern electrical systems has led to a surge in harmonic distortions, posing challenges to the overall power quality. In response to this, active power filters (APFs) have emerged as indispensable devices for mitigating harmonic currents and enhancing the performance of electrical networks. Among the various modulation techniques employed in APFs, the Asymmetric Selective Harmonic Current Mitigation Pulse Width Modulation (PWM) technique has gained significant attention for its unique capabilities in targeted harmonic reduction.

The conventional PWM techniques often face limitations in selectively mitigating specific harmonic components, especially in asymmetrical systems where harmonic sources exhibit distinct characteristics. Asymmetric Selective Harmonic Current Mitigation-PWM addresses these challenges by offering a tailored approach to harmonic mitigation, focusing on the suppression of harmonics relevant to the specific harmonic profile of the system under consideration.

This review comprehensively explores the principles that underlie Asymmetric Selective Harmonic Current Mitigation-PWM, providing a detailed examination of how this technique effectively targets and reduces asymmetrical harmonic components. The paper investigates the advantages of employing Asymmetric Selective Harmonic Current Mitigation-PWM in comparison to traditional modulation methods, highlighting its potential to enhance the overall performance of active power filters.

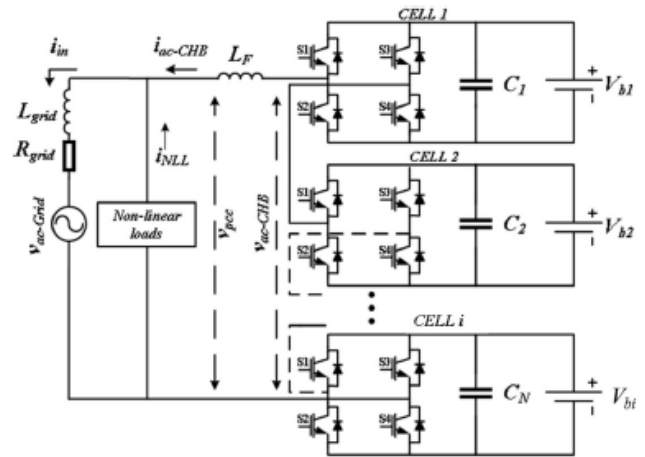

Figure 1: Cascaded H-Bridge [1]

Moreover, the review delves into recent advancements in the field, discussing innovative strategies and technological



International Journal of Recent Development in Engineering and Technology

Website: www.ijrdet.com (ISSN 2347 - 6435 (Online) Volume 13, Issue 6, June 2024)

developments that further refine the capabilities of Asymmetric Selective Harmonic Current Mitigation-PWM. In addition to the benefits, the paper critically examines the challenges associated with the implementation of this technique, addressing issues such as control complexity, hardware requirements, and potential interactions with other power quality enhancement devices.

As the landscape of power electronics and harmonic mitigation continues to evolve, this review aims to provide a comprehensive understanding of the current state of Asymmetric Selective Harmonic Current Mitigation-PWM in active power filters. By shedding light on both the achievements and challenges, the paper seeks to guide future research endeavors, offering valuable insights into potential avenues for advancing the effectiveness and efficiency of harmonic mitigation strategies in modern electrical systems.

II. LITERATURE SURVEY

A. Moeini et al., [1] Controlling the harmonics of nonlinear loads in power systems is the purpose of an active power filter, often known as an APF. Additionally, the reactive power, which is a basic component of the alternating current (AC) power, may be compensated for by using an active power filter (APF) at the point of common coupling (PCC). The modulation method of active power filters is the subject of this research, which examines a technique for the technique.

L. Zhang et al. [2] presented strategy is to suppress high-order harmonics in order to meet the requirements of power quality standards and to solve the problem of power mismatching that occurs in asymmetric multilevel inverters. The asymmetric cascaded H-bridge (ACHB) multilevel inverter serves as the foundation for this method, which is based on an asymmetric dc-link voltage applied. First, a novel harmonic mitigation model that is based on the power matching control is developed, and then a theoretical analysis of the output active power of each H-bridge cell is performed. Second, switching angles may be produced by translating multiobjective inequality problems of ASHM-PWM into single objective equation groups and then combining this with improved particle swarm optimization (IPSO), which can make the process of solving the issue more straightforward.

C. Zhang et al. [3] multifunction parallel three-level four-leg converters are suggested for use in high-power applications. These converters integrate grid-connected renewable energy with active power filter (APF) technology. However, the problem of zero-sequence circulating current (ZSCC) is unavoidable, and it has the effect of lowering the quality of the output currents and decreasing the system's stability. An article is presented in which a proportional integral (PI) plus feedforward control method and space vector modulation that is based on nonaxial redundant vectors (NARVs) are provided as a means of overcoming this constraint. To begin, the ZSCC model is constructed and then subjected to a comprehensive analysis. As a result of the investigation, it has been discovered that the zero-sequence duty-cycle difference and the zero-sequence benchmark function are the factors that define ZSCC.

S. P. Biswas et al., [4] In the SMES/HTS based grid-tied power system, the method of pulse width modulation (PWM) that is used for the switching of the voltage source converter (VSC) has a considerable influence on the joules heating, switching and conduction power losses, total harmonic distortion (THD) profile of the VSC output, and conversion efficiency. For a VSC-based grid-tied photovoltaic (PV) system, a modified reference saturated third harmonic injected equal loading pulse width modulation (PWM) approach is suggested in this study.

B. Zhang et al., [5] resonant current mitigation, removal of current zero-crossing distortion, neutral point (NP) voltage balancing, and switching loss reduction are some of the challenges that the Vienna rectifier faced when it was equipped with the LCL filter. A further point to consider is that these issues are intertwined. The reasons of resonant current using the standard discontinuous pulsewidth modulation (PWM) (DPWM) technique are investigated in order to find a solution to these problems. The findings of this analysis indicate that the sudden change in reference voltage has a broad range of harmonics band and readily generates the resonant current at the resonant frequency. After that, a unique three-layer DPWM approach with three offset voltages injection is presented. This method is based on the analysis mentioned before. The NP voltage balance is achieved in the first layer with the injection of the initial offset voltage.



Presented in the second layer is the second offset voltage, which smoothes out the discontinuous reference voltages.

A. Mishra et al., [6] An investigation into the performance analysis of two-stage solar photovoltaic (PV) systems that have been combined with a Shunt Active Harmonic Filter (SAHF) is presented in this article. Due to the widespread use of non-linear loads, the distributed power system has been impacted by the present harmonic issue within the context of the recent industrial revolution. For the purpose of load adjustment, harmonic mitigation, and power factor correction, the SAHF system is of great assistance. A three-leg Voltage Source Converter and DC power collected from the PV module are used in the construction of the SAHF system.

B. Wang et al., [7] The method of turn fault detection is of critical significance for the safety of the system, as it has the potential to safeguard the machine and allow the implementation of suitable mitigation techniques. An enhanced turn defect detection approach is examined for an internal permanent magnet machine (IPM) in this research. The method makes use of the ripple current that is caused by the intrinsic pulse width modulation (PWM) voltage harmonics. Under high-frequency voltage harmonics, the resulting current harmonics are studied for both healthy and turn fault states. This is done in preparation for the analysis. In order to verify the practicability of the detection approach, simulation studies and prototype testing are taken into consideration.

R. Shen et al., [8] presented a single-phase transformerless full-bridge solar grid-tie inverter. It makes use of three different methods: 1) a virtual ground technique to reduce the amount of ground leakage current; 2) a hybrid pulsewidth modulation (HPWM) scheme to profile the output current and prevent sudden changes in the common-mode voltage; and 3) a nonlinear output inductor to reduce the amount of current ripple around zero crossings and to reduce the size of the filter. With the addition of gentle voltage transition modulation around the zero crossings, the high-power pulse width modulation (HPWM) is essentially the same as the unipolar pulse width modulation (UPWM). The output filter is designed to provide maximum attenuation of ripple current while simultaneously minimizing switching losses.

R. Sarker et al., [9] presented a novel field-programmable gate array (FPGA) based high-definition pulse width modulation (HD-SPWM) architecture. The purpose of this architecture is to adopt a scheme that integrates a lower frequency pulse width modulation (PWM) train with a high-frequency SPWM train. The goal of this architecture is to suppress inverter output harmonics while simultaneously achieving high resolution output. An optimized two-stage finite-state-machine (FSM) architecture is designed. In the first stage, the pulsewidths of a lower frequency pulse width modulation (PWM) train are determined based on the premeditated pulsewidth of the high-frequency pulse width modulation (SPWM) train. In the final stage, the pulsewidths of lower frequency PWM are integrated with the pulsewidths of high-frequency SPWM to generate updated pulsewidths of high-frequency SPWM, also known as HD-SPWM.

A. Moeini et al., [10] presented energy storage systems and renewable energy sources, multilevel converters are becoming an increasingly intriguing option. There are a number of different modulation techniques that are utilized for multilevel grid connected converters in the literature. These techniques include high-frequency modulation approaches, such as space vector modulation and phase shift-PWM, as well as low-frequency modulation approaches, such as selective harmonic current mitigation-PWM (SHCM-PWM), selective harmonic mitigation-PWM (SHM-PWM). By using the low-frequency modulation techniques, it is possible to obtain high efficiency, which is characterized by reduced switching losses.

III. CHALLENGES

Challenges in Implementing Asymmetric Selective Harmonic Current Mitigation-PWM in Active Power Filters:

1. **Control Complexity:**

The implementation of Asymmetric Selective Harmonic Current Mitigation-PWM introduces complexities in control algorithms. Achieving optimal harmonic mitigation while considering asymmetrical conditions requires sophisticated control strategies, posing challenges in design and implementation.

2. **Adaptability to Variable Load Conditions:**



International Journal of Recent Development in Engineering and Technology

Website: www.ijrdet.com (ISSN 2347 - 6435 (Online) Volume 13, Issue 6, June 2024)

Asymmetric loads and variable operating conditions in electrical systems can present challenges for maintaining the efficacy of Asymmetric Selective Harmonic Current Mitigation-PWM. Ensuring adaptability to dynamic load profiles and accommodating changes in the harmonic spectrum is essential for sustained performance.

3. Interaction with Other Power Quality Devices:

Active power filters are often part of a broader power quality improvement strategy that includes other devices such as static compensators or voltage regulators. The potential interactions and coordination challenges between Asymmetric Selective Harmonic Current Mitigation-PWM and these devices need careful consideration to avoid conflicts and ensure seamless operation.

4. Robustness and Reliability:

The robustness of Asymmetric Selective Harmonic Current Mitigation-PWM under diverse operating conditions is crucial. The system must reliably detect and mitigate harmonics, even in the presence of disturbances, variations in load characteristics, and transient events.

5. Modeling and Simulation Challenges:

Developing accurate mathematical models for systems with asymmetric loads and applying these models to simulate the behavior of Asymmetric Selective Harmonic Current Mitigation-PWM can be challenging. Real-world conditions may introduce complexities that are difficult to capture in theoretical models.

6. Standardization and Interoperability:

The absence of standardized testing procedures and performance metrics specific to Asymmetric Selective Harmonic Current Mitigation-PWM can hinder its widespread adoption. Establishing industry standards and ensuring interoperability with existing power quality solutions is essential for seamless integration into diverse electrical systems.

7. Maintenance and Fault Diagnosis:

Ensuring the long-term reliability of Asymmetric Selective Harmonic Current Mitigation-PWM requires effective maintenance strategies and fault diagnosis mechanisms. Rapid

detection and rectification of issues, such as component failures or degradation, are critical for sustained performance.

IV. ADVANCEMENTS AND POTENTIAL FUTURE DIRECTIONS

Advancements in Asymmetric Selective Harmonic Current Mitigation-PWM and Potential Future Directions:

1. Advanced Control Algorithms:

Ongoing research focuses on developing advanced control algorithms for Asymmetric Selective Harmonic Current Mitigation-PWM. Adaptive control strategies, artificial intelligence-based approaches, and machine learning techniques are explored to enhance the adaptability and performance of the modulation technique.

2. Hybrid Modulation Techniques:

Researchers are investigating hybrid modulation techniques that integrate Asymmetric Selective Harmonic Current Mitigation-PWM with other established methods. Combining the strengths of multiple modulation strategies may result in improved harmonic mitigation across a broader range of operating conditions.

3. Integration with Smart Grid Technologies:

As power systems evolve towards smarter grids, the integration of Asymmetric Selective Harmonic Current Mitigation-PWM with smart grid technologies becomes a focus. This includes seamless communication, coordination with grid management systems, and participation in demand response programs.

4. Harmonic Resonance Mitigation:

Beyond addressing individual harmonics, advancements target the mitigation of harmonic resonances in the power system. Asymmetric Selective Harmonic Current Mitigation-PWM is explored for its potential in suppressing resonance phenomena and ensuring stability in the presence of resonance conditions.

V. CONCLUSION

The exploration of Asymmetric Selective Harmonic Current Mitigation-PWM in active power filters represents a dynamic and evolving field at the forefront of power electronics and harmonic mitigation. This review has delved into the

principles, challenges, and advancements surrounding this innovative modulation technique, offering valuable insights into its potential applications and future directions. The identified challenges, ranging from control complexities to hardware requirements and adaptability to variable load conditions, underscore the need for continuous research and development. These challenges, however, are met with promising advancements and ongoing efforts aimed at overcoming obstacles, enhancing control algorithms, and ensuring robust and reliable performance.

REFERENCES

1. A. Moeini, M. Dabbaghjamanesh, J. W. Kimball and J. Zhang, "Artificial Neural Networks for Asymmetric Selective Harmonic Current Mitigation-PWM in Active Power Filters to Meet Power Quality Standards," in *IEEE Transactions on Industry Applications*, doi: 10.1109/TIA.2020.3007596.
2. L. Zhang, W. Hong, C. Gao, R. Liu, Q. Yu and C. Wei, "Selected Harmonic Mitigation PWM Power Matching Control Strategy for Asymmetric Cascaded H-Bridge Multilevel Inverter," in *IEEE Journal of Emerging and Selected Topics in Power Electronics*, vol. 10, no. 4, pp. 4059-4072, Aug. 2022, doi: 10.1109/JESTPE.2021.3137337.
3. C. Zhang, R. Zhang, X. Xing and X. Li, "Circulating Current Mitigation and Harmonic Current Compensation for Multifunction Parallel Three-Level Four-Leg Converters," in *IEEE Journal of Emerging and Selected Topics in Power Electronics*, vol. 10, no. 3, pp. 2805-2818, June 2022, doi: 10.1109/JESTPE.2021.3072437.
4. S. P. Biswas et al., "A Modified Reference Saturated Third Harmonic Injected Equal Loading PWM for VSC-Based Renewable Energy Systems," in *IEEE Transactions on Applied Superconductivity*, vol. 31, no. 8, pp. 1-5, Nov. 2021, Art no. 5000405, doi: 10.1109/TASC.2021.3096484.
5. B. Zhang, C. Zhang, X. Xing, X. Li and Z. Chen, "Novel Three-Layer Discontinuous PWM Method for Mitigating Resonant Current and Zero-Crossing Distortion in Vienna Rectifier With an LCL Filter," in *IEEE Transactions on Power Electronics*, vol. 36, no. 12, pp. 14478-14490, Dec. 2021, doi: 10.1109/TPEL.2021.3088610.
6. A. Mishra, S. Chauhan, P. Karuppanan and M. Suryavanshi, "PV based Shunt Active Harmonic Filter for Power Quality improvement," 2021 International Conference on Computing, Communication, and Intelligent Systems (ICCCIS), Greater Noida, India, 2021, pp. 905-910, doi: 10.1109/ICCCIS51004.2021.9397214.
7. B. Wang, L. Luo, W. Fu, W. Hua, G. Wang and Z. Wang, "Study on the PWM Ripple Current Based Turn Fault Detection for Interior PM Machine," in *IEEE Transactions on Transportation Electrification*, vol. 7, no. 3, pp. 1537-1547, Sept. 2021, doi: 10.1109/TTE.2021.3050560.
8. R. Shen and H. S. -H. Chung, "Mitigation of Ground Leakage Current of Single-Phase PV Inverter Using Hybrid PWM With Soft Voltage Transition and Nonlinear Output Inductor," in *IEEE Transactions on Power Electronics*, vol. 36, no. 3, pp. 2932-2946, March 2021, doi: 10.1109/TPEL.2020.3016867.
9. R. Sarker, A. Datta and S. Debnath, "FPGA-Based High-Definition SPWM Generation With Harmonic Mitigation Property for Voltage Source Inverter Applications," in *IEEE Transactions on Industrial Informatics*, vol. 17, no. 2, pp. 1352-1362, Feb. 2021, doi: 10.1109/TII.2020.2983844.
10. A. Moeini, M. Dabbaghjamanesh and J. W. Kimball, "Q-Learning-Based Smart Selective Harmonic Current Mitigation-PWM (S2HCM-PWM) for Grid-Connected Converters," 2020 IEEE Energy Conversion Congress and Exposition (ECCE), Detroit, MI, USA, 2020, pp. 5068-5075, doi: 10.1109/ECCE44975.2020.9236369.